

# ATR 72-600 LOPA for NAC / BRAATHENS – MSN 1598

LOPA 72 Pax seats at 29" pitch, Cabin layout non "HIC" compliant (CS25.562(c))

Front/LH cargo door, fwd straight cabin partition

"Armonia" cabin interiors, Geven "Neo-Prestige" (recline except on last rows (special upright)) pax seats

"A+K" SMART Galley type

Dual or single Collins HF9000 provision



## Legend:

### Overall Cabin (refer to drawing)

- A Cabin attendant seat
- B Baggage compartment
- CD Cargo door
- ▲ Emergency exit
- RD Rear door
- SD Service door
- T Toilet
- G ( ) Galley (Galley Type)
- C Coatroom

### Passenger Seats (refer to seats specification)

- IAT In-arm table
- STD Standard
- LR Last row
- LH/RH Left / Right hand side
- DPA Disabled people armrest
- BO Break over

### Galley Equipment (refer to galleys description)

- W Waste Bin
- B Basin
- S/U Standard unit (x4)
- ½ T Half Trolley (x3)
- S Stowage (x5)
- H/J Hot jug (x2)

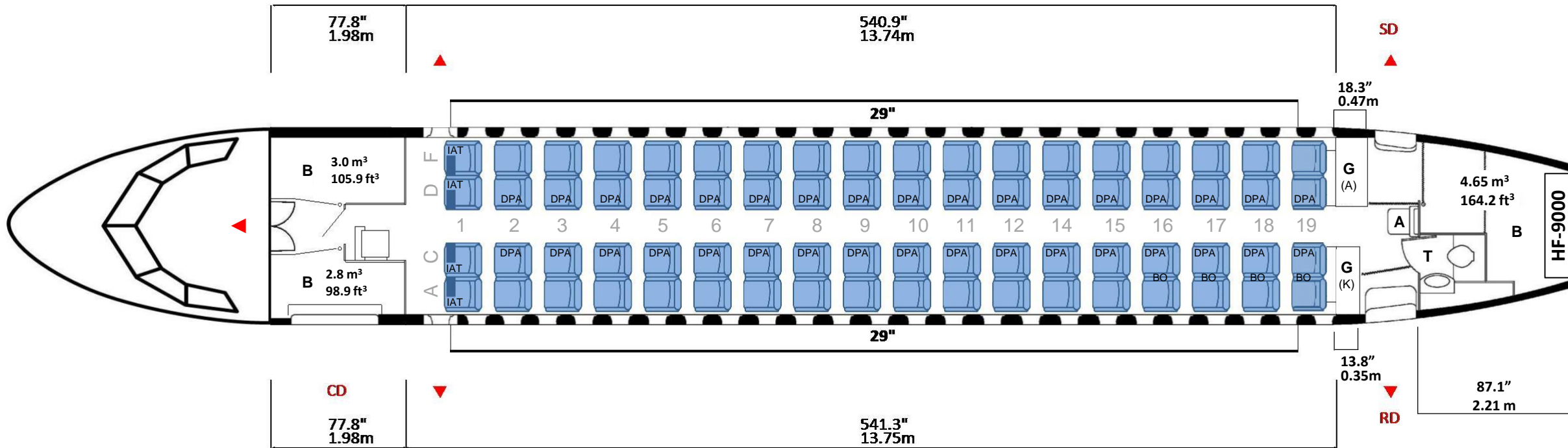

Baggage Volumes	m <sup>3</sup>	ft <sup>3</sup>
Baggage compartments	10,45	369,0
Baggage / pax	0,145	5,12
Total baggage (incl. overhead bins)	13,71	484,3
Total Baggage / pax	0,190	6,72

### Seats Specification (from front to rear of cabin)

Description	Part Number	Qty
GEVEN NEO-PRES IAT RH	D5-02-012-1DN	1
GEVEN NEO-PRES IAT LH	D5-02-011-1DN	1
GEVEN NEO-PRES STD DPA RH	D5-02-014-1DN	16
GEVEN NEO-PRES STD DPA LH	D5-02-013-1DN	13
GEVEN NEO-PRES STD DPA BO LH	D5-02-015-1DN	3
GEVEN NEO-PRES LR DPA RH	D5-02-904-1DN	1
GEVEN NEO-PRES LR DPA BO LH	D5-02-901-1DN	1

### Smart Galleys Description: A02/1 + K1/1

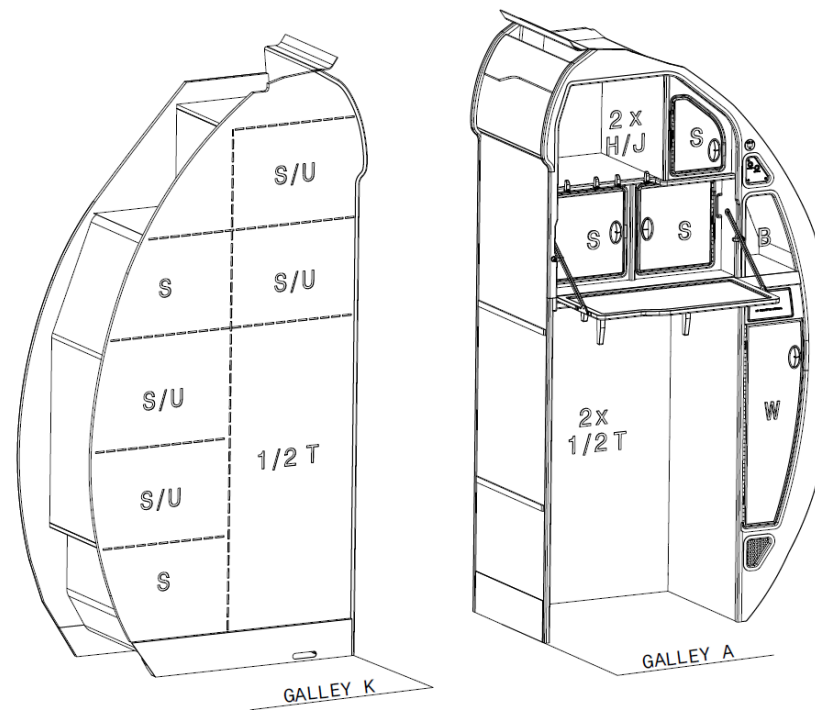

Rev 1	09/08/2022
Author	ATR / CCA Dpt / A. LADARRÉ
Source	As per Contractual Specification
Chrono number	CCA-379/22